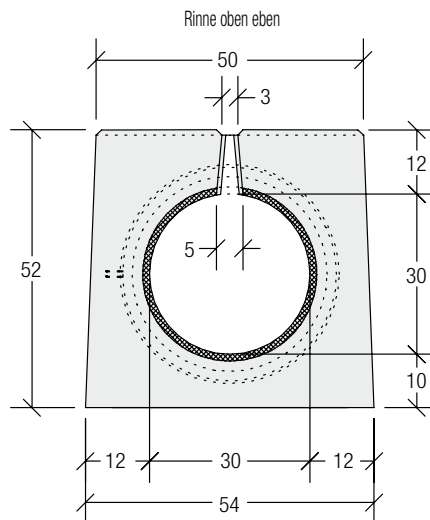

CHEM 300

- mit unterbrochenem Schlitz
- Rinnenoberfläche eben
- ohne Innengefälle

Rinne ohne Innengefälle

Belastungsklasse	D, F
Außenabmessungen	50/54 x 52 cm
Schlitzweite	3(-1,5)/5 cm
Gerinneabmessungen	30 cm
Abflussquerschnitt	706 cm ²
Baulänge Standardrinne	3,99 m
Gewicht Standardrinne	ca. 1.880 kg
Systemlänge	4,00 m

Draufsicht

